



Arcom Communications
24035 NE Butteville Rd
Aurora, Oregon 97002
(503) 678-6182

sales@arcomcontrollers.com

<http://www.arcomcontrollers.com/>

ADR Interface for the Yaesu DR1x

The ADR Interface allows the connection of an external repeater controller to the Yaesu DR-1x Fusion Repeater while still retaining the automatic mode selection capability of the repeater as well as preventing conflict between the DR1x and your external controller.

While the ADR was designed for use with our RC210 in mind, it will work with any repeater controller on the market.

Connecting the ADR

If you purchased the complete ADR package, you simply connect the cable with the DB15 to the connector on the back of the DR-1x. The other cable has a DB9 connector, wired for our RC210 and you simply plug it into whichever Port of the RC210 you're planning to use. If you're using a controller other than the RC210, you will need to rewire this connector as needed. **COS and CTCSS Polarity settings for both MUST be set to Active Low.** Also, if your controller doesn't support the control of an external Tone Encoder, you must ground the Orange/white wire of the TS64WDS in order to allow the Tone Encoder to generate tone.

You will need to remove the cover in order to gain access to a cable within the DR1x that must be modified. Once the cover is removed, you'll see a cable that is plugged into the back of the transmitter chassis that runs over to the receiver chassis. If you purchased our complete plug-and-play version, simply disconnect this cable (at the transmitter end and modify it as shown at the following link:

You can see photos of how to modify the cable at the following URL:

http://www.arcomcontrollers.com/index.php?option=com_content&view=article&id=115:modifying-dr1-x-cable-to-obtain-ptt&catid=79:home-page

You will need to cut into the cable (carefully!) and tap a wire off the yellow wire contained within the cable. Route the wire from the tap outside of the DR-1x through the vent holes (near the center of the rear panel) and connect to the connector protruding from the DB15 shell, using the mating connector supplied with your ADR. Replace the cover on the DR-1x.

DR1x Configuration

The DR-1x **MUST** be properly configured in order to work properly with an external controller and still retain its Fusion Digital capability. Be sure to observe the following DR1x settings:

Remote = ON

R = DCS

T = OFF

SIGNALLING = anything but a valid tone (any tone OTHER than what you're using) or DCS code

DSQ CODE = OFF

TOT and other settings can be whatever you want.

Adjustments

The only adjustments that need to be made is the Tone Encode Level output from the TS64WDS and selecting the proper tone via its dipswitch (by default, the TS64WDS ships with its tone set to 250.3 Hz and the level at full). Refer to the TS64WDS manual that came with your ADR. Adjust as needed to deviate your DR-1x at 600 Hz. If you purchased the Plug-and-Play version, you will need to remove the 4 screws from the plastic box in order to make these adjustments. Replace after that is done.

Note: You may notice a loud "hum" before you select your own CTCSS tone and properly adjust the TS64's level control. This is normal

Note: You MUST use CTCSS access and cannot use Carrier Only Access. Select your controller's configuration as needed

Note: COS and CTCSS Polarity settings for both MUST be set to Active Low

Building the cables between the ADR and your controller/DR1-X

If you didn't purchase the complete Plug-and-Play version, you will need to fabricate your own cabling. The ADR schematic shows the pinout and connections that need to be made. It is suggested you use shielded cable for both cables (ADR to DR1-X and ADR to controller). Holes are provided in the pc board for strain relief using plastic zip straps

Parts list

C1, C2 .1 uf
IC1 Custom Arcom-programmed microprocessor
IC2 74LS05 5v, 100 ma voltage regulator
C3 wire jumper
R1 Not used

If complete Plug-and-Play version:

15" cable with DB15 (to DR1-X)
15" cable with DB9 (to controller)
Communications Specialists TS-64WDS

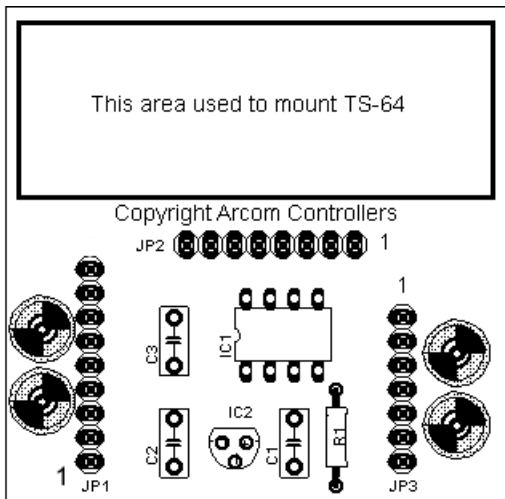

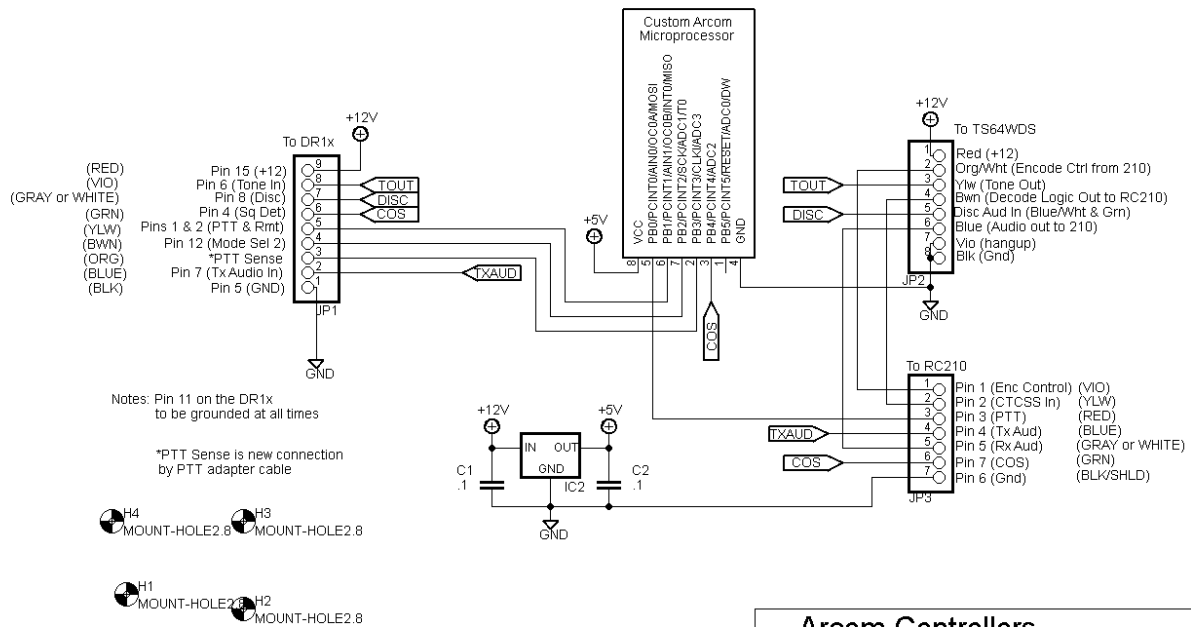

Arcom Controllers Yaesu DR1x Interface	
TITLE: DR1-x	
Document Number:	REV: 1.0
Date: not saved!	Sheet: 1/1

Model TS-64WDS

Miniature 64 Tone CTCSS Encoder-Decoder with Dip Switch

The Communications Specialists Model TS-64WDS Miniature 64 Tone CTCSS Encoder-Decoder is a microprocessor based product used for encoding and decoding subaudible tones. The TS-64WDS is compatible with continuous tone controlled squelch systems (CTCSS) used in land mobile radio such as 'Private Line', 'Channel Guard', and 'Quiet Channel'.

Because of its small size and low power consumption, advanced engineering has resulted in a product that is ideal for mobile and portable two-way FM radio installations. Simple field programming by a miniature dip switch and jumper pads allows the radio service shop to configure the CTCSS tone, Transmit Time-out-timer, Hang-up/Busy function, and on board LED indicator. Squelch tail elimination is achieved by the use of a 'reverse phase burst' at the end of each transmission. An audio high pass filter eliminates the CTCSS signal from the recovered audio.

Section	Description
1.0	Operating Instructions
2.0	Programming the TS-64WDS
2.1	CTCSS tone programming
2.2	Transmit time-out-timer programming
2.3	PCB LED indicator
3.0	Installation Instructions
3.1	Adjustment
4.0	Specifications

1.0 OPERATING INSTRUCTIONS

The TS-64WDS is designed to encode and decode CTCSS transmissions in conjunction with an associated FM radio transceiver. Upon receipt of a programmed CTCSS coded transmission, the TS-64WDS will unmute the receiver audio and allow audio to pass. While the TS-64WDS is decoding, an internal timer keeps the audio path open for approximately 350 ms during a loss of signal due to signal fade. Upon receipt of the turn off code, the TS-64WDS will immediately mute the receiver audio thus eliminating the squelch tail that is usually heard at the end of a transmission. The microphone Hang-up Input allows the operator to override the decoder and open up the audio path for channel monitoring.

When the PTT switch is keyed on the microphone, the TS-64WDS will key the transmitter and immediately begin generating the programmed CTCSS tone for transmission. The TS-64WDS will continue to generate the CTCSS tone for as long as the PTT switch is pressed. Upon release of the PTT switch, the TS-64WDS will continue to key the transmitter for approximately 160 ms. During this time, the TS-64WDS will generate a reverse phase burst which will mute the decoding unit at the other end of the transmission medium. At the end of the 160 ms period, the TS-64WDS will unkey the transmitter. If activated, an internal Transmit Time-out-timer will limit transmissions to a programmed length, thus eliminating problems with stuck microphones and the like.

2.0 PROGRAMMING THE TS-64WDS

This section of the instructions describes how to program the TS-64WDS to suit the needs of your radio system. These programming features are designed to be programmed by the installing technician. The TS-64WDS may be programmed before or after it is installed in the associated radio set. The TS-64WDS is programmed by the dip switch (setting CTCSS tone frequency) and installing 'solder bridges' across the four jumper pads, T01, T02, T03 and H/B (hang-up/busy) if needed. A low wattage soldering iron with a small tip should be used to place a small solder bridge across the various jumper pads. When programming the unit, be careful not to damage the TS-64WDS printed circuit board. The TS-64WDS comes from the factory with the jumper pads all open, which is the most common configuration. See the Parts Layout Diagram for the location of the jumper pads.

2.1 CTCSS TONE PROGRAMMING

CTCSS tone frequency is programmed using the miniature dip switch. A total of 64 different subaudible tones can be selected. Simply slide each of the 6 switches either ON or OFF to select the desired frequency. The table to the right shows the switch positions required to select each CTCSS tone frequency. Please note that tones marked with a "*" are not EIA tones, should only be used for special applications, and may not work in harmony with adjacent EIA tones.

2.2 TRANSMIT TIME-OUT-TIMER PROGRAMMING

The Transmit time-out-timer is used to limit the duration of a continuous transmission to a maximum length as programmed by the jumper pads T01, T02, and T03. The timer can be programmed with eight different timeout intervals. These are listed in the table below. The Transmit time-out-timer is disabled when received from the factory.

TIMEOUT INTERVAL	T01	T02	T03
DISABLED	out	out	out
15 seconds	bridge	out	out
30 seconds	out	bridge	out
45 seconds	bridge	bridge	out
1 minute	bridge	out	bridge
2 minutes	out	bridge	bridge
3 minutes	out	out	bridge
5 minutes	bridge	bridge	bridge

2.3 PCB LED INDICATOR

There is a small green LED on the component side of the TS-64WDS PCB to indicate status. There are 3 jumper pads on the bottom side of the PCB that can have a "solder bridge" installed between the center pad and either or both of the other 2 pads to indicate status as follows:

Center pad to MUTE 2 LED pad=LED only on when decoding or mike is off-hook (as shipped)
 Center pad to MUTE 1 LED pad=LED only off when decoding or mike is off-hook
 Center pad to both MUTE 2 and MUTE 1 pads=LED is a power on indicator only
 Center pad not bridged=LED is always off

Tone	#1	#2	#3	#4	#5	#6
33.0*	OFF	ON	ON	OFF	OFF	OFF
35.4*	ON	ON	ON	OFF	OFF	OFF
36.6*	OFF	OFF	OFF	ON	OFF	OFF
37.9*	ON	OFF	OFF	ON	OFF	OFF
39.6*	OFF	ON	OFF	ON	OFF	OFF
44.4*	ON	ON	OFF	ON	OFF	OFF
47.5*	OFF	OFF	OFF	ON	ON	OFF
49.2*	ON	OFF	OFF	ON	ON	OFF
51.2*	OFF	ON	OFF	ON	ON	OFF
53.0*	ON	ON	OFF	ON	ON	OFF
54.9*	OFF	OFF	ON	ON	ON	OFF
56.8*	ON	OFF	ON	ON	ON	OFF
58.8*	OFF	ON	ON	ON	ON	OFF
63.0*	ON	ON	ON	ON	ON	OFF
67.0	OFF	OFF	OFF	OFF	OFF	OFF
69.4*	ON	ON	ON	OFF	ON	OFF
71.9	OFF	OFF	OFF	OFF	OFF	ON
74.4	ON	OFF	OFF	OFF	OFF	OFF
77.0	OFF	OFF	OFF	OFF	ON	ON
79.7	OFF	ON	OFF	OFF	OFF	OFF
82.5	ON	OFF	OFF	OFF	OFF	ON
85.4	ON	ON	OFF	OFF	OFF	OFF
88.5	ON	OFF	OFF	OFF	ON	ON
91.5	OFF	OFF	ON	OFF	OFF	OFF
94.8	OFF	ON	OFF	OFF	OFF	ON
97.4*	ON	OFF	ON	OFF	OFF	OFF
100.0	OFF	ON	OFF	OFF	ON	ON
103.5	ON	ON	OFF	OFF	OFF	ON
107.2	ON	ON	OFF	OFF	ON	ON
110.9	OFF	OFF	ON	OFF	OFF	ON
114.8	OFF	OFF	ON	OFF	ON	ON
118.8	ON	OFF	ON	OFF	OFF	ON
123.0	ON	OFF	ON	OFF	ON	ON
127.3	OFF	ON	ON	OFF	OFF	ON
131.8	OFF	ON	ON	OFF	ON	ON
136.5	ON	ON	ON	OFF	OFF	ON
141.3	ON	ON	ON	OFF	ON	ON
146.2	OFF	OFF	OFF	ON	OFF	ON
151.4	OFF	OFF	OFF	ON	ON	ON
156.7	ON	OFF	OFF	ON	OFF	ON
159.8*	OFF	ON	ON	OFF	ON	OFF
162.2	ON	OFF	OFF	ON	ON	ON
165.5*	ON	OFF	ON	OFF	ON	OFF
167.9	OFF	ON	OFF	ON	OFF	ON
171.3*	OFF	OFF	ON	OFF	ON	OFF
173.8	OFF	ON	OFF	ON	ON	ON
177.3*	ON	ON	OFF	OFF	ON	OFF
179.9	ON	ON	OFF	ON	OFF	ON
183.5*	OFF	ON	OFF	OFF	ON	OFF
186.2	ON	ON	OFF	ON	ON	ON
189.9*	ON	OFF	OFF	OFF	ON	OFF
192.8	OFF	OFF	ON	ON	OFF	ON
196.6*	OFF	OFF	OFF	OFF	ON	OFF
199.5*	ON	ON	ON	ON	OFF	OFF
203.5	OFF	OFF	ON	ON	ON	ON
206.5*	OFF	ON	ON	ON	OFF	OFF
210.7	ON	OFF	ON	ON	OFF	ON
218.1	ON	OFF	ON	ON	ON	ON
225.7	OFF	ON	ON	ON	OFF	ON
229.1*	ON	OFF	ON	ON	OFF	OFF
233.6	OFF	ON	ON	ON	ON	ON
241.8	ON	ON	ON	ON	OFF	ON
250.3	ON	ON	ON	ON	ON	ON
254.1*	OFF	OFF	ON	ON	OFF	OFF

*NON EIA STANDARD TONES



COMMUNICATIONS SPECIALISTS, INC.
 426 WEST TAFT AVENUE • ORANGE, CA 92865-4296
 714.998.3021 • FAX 714.974.3420
 US & CANADA 800.854.0547 • FAX 800.850.0547
 www.com-spec.com Email: sales@com-spec.com